

# XECARB® 28-C20-3DP

20% carbon fiber reinforced ABS, 3D printing modified

Physical properties	Test condition	Standard	Unit	Dam / Cond.
Density		ISO 1183	g/cm <sup>3</sup>	<b>1,12</b>
Water absorption (Equilibrium value)	23 °C ; 50 % RH		%	
Water absorption (Saturation value)	23°C ; H <sub>2</sub> O		%	
Post-shrinkage				
parallel		Sim. ISO 294-4	%	
normal		Sim. ISO 294-4	%	

## Mechanical properties – Injection molded

Tensile modulus	1 mm/min	ISO 527	MPa	<b>14000</b>
Tensile strength at break	5 mm/min	ISO 527	MPa	<b>110</b>
Tensile elongation at break	5 mm/min	ISO 527	%	<b>1,2</b>
Flexural modulus	2 mm/min	ISO 178	MPa	<b>10000</b>
Flexural strength	2 mm/min	ISO 178	MPa	<b>140</b>
Flexural stress at 3.5% strain	2 mm/min	ISO 178	MPa	
Flexural strain at break	2 mm/min	ISO 178	%	<b>1,8</b>
Notched Izod impact strength	23 °C ; 50 % RH	ISO 180	kJ/m <sup>2</sup>	<b>6</b>
Unnotched Izod impact strength	23 °C ; 50 % RH	ISO 180	kJ/m <sup>2</sup>	<b>15</b>

## Mechanical properties – 3D printed

Tensile modulus				
Longitudinal	1 mm/min	ISO 527	MPa	<b>12000</b>
Transversal	1 mm/min	ISO 527	MPa	<b>4000</b>
Tensile strength at break				
Longitudinal	5 mm/min	ISO 527	MPa	<b>90</b>
Transversal	5 mm/min	ISO 527	MPa	<b>30</b>
Tensile elongation at break				
Longitudinal	5 mm/min	ISO 527	%	<b>1,0</b>
Transversal	5 mm/min	ISO 527	%	<b>0,9</b>
Flexural modulus				
Longitudinal	2 mm/min	ISO 178	MPa	<b>9000</b>
Transversal	2 mm/min	ISO 178	MPa	<b>4000</b>
Flexural strength				
Longitudinal	2 mm/min	ISO 178	MPa	<b>140</b>
Transversal	2 mm/min	ISO 178	MPa	<b>50</b>

## Thermal properties

Melting point	10 °C/min	ISO 11357	°C	
HDT – heat deflection temperature	0,45 MPa a 120 °C/h	ISO 75	°C	
HDT – heat deflection temperature	1,80 MPa a 120 °C/h	ISO 75	°C	<b>110</b>
HDT – heat deflection temperature	8.00 MPa a 120 °C/h	ISO 75	°C	

# XECARB<sup>®</sup> 28-C20-3DP

20% carbon fiber reinforced ABS, 3D printing modified

## Process recommendation

	Test condition	Standard	Unit	Value
Drying temperature	desiccant dryer		°C	<b>80–100</b>
Drying time	desiccant dryer		h	<b>6–8</b>
Melt temperature			°C	<b>240</b>
Nozzle temperature			°C	<b>270</b>
Bed temperature			°C	<b>100</b>

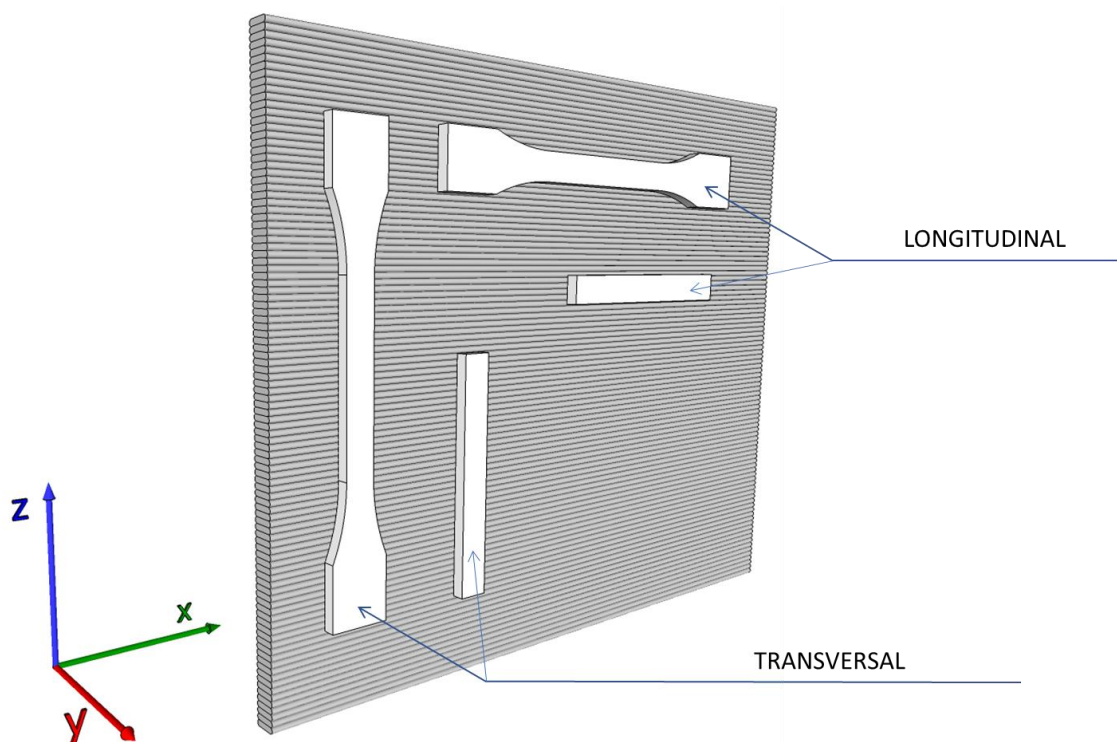

Our advice does not release you from the obligation to verify the information currently provided - especially that contained in our safety data and technical information sheets, and to test our products as to their suitability for the intended processes and uses. The application, use and processing of our products and the products manufactured by you on the basis of our technical advice are beyond our control and, therefore, entirely your own responsibility. Our products are sold in accordance with the current version of our General Conditions of Sale and Delivery.

### Test values

Unless specified to the contrary, the values given have been established on standardized test specimens at room temperature. The figures should be regarded as guide values only and not as binding minimum values. Kindly note that, under certain conditions, the properties can be affected to a considerable extent by the design of the mould/die, the processing conditions and the coloring.

### Processing note

Under the recommended processing condition small quantities of decomposition product may be given off during processing. To preclude any risk to the health and well-being of the machine operatives, tolerance limits for the work environment must be ensured by the provision of efficient exhaust ventilation and fresh air at the workplace in accordance with the Safety Data Sheet. In order to prevent the partial decomposition of the polymer and the generation of volatile decomposition products, the prescribed processing temperatures should not be substantially exceeded. Since excessively high temperatures are generally the result of operator error or defects in the heating system, special care and controls are essential in these areas.

Edition: November 2022